

On-board DC/DC converter

1. Overview

DCT-1000 Series of 1000W Series DC/DC converter can be installed in electric cars to supply 12V low-voltage DC power to be used for low-voltage equipment. The output terminal can connect a backup 12V battery and DC/DC converter can manage the charging of the backup battery automatically. The casing is fully sealed, water-proof, automotive level temperature resistance and vibration resist. Connection diagram as illustrated below. The high voltage DC input of the DC/DC converter connects directly to the positive and negative pole of the battery pack and the DC output connects to the 12V backup battery, then export to all the 12V electrical appliances.

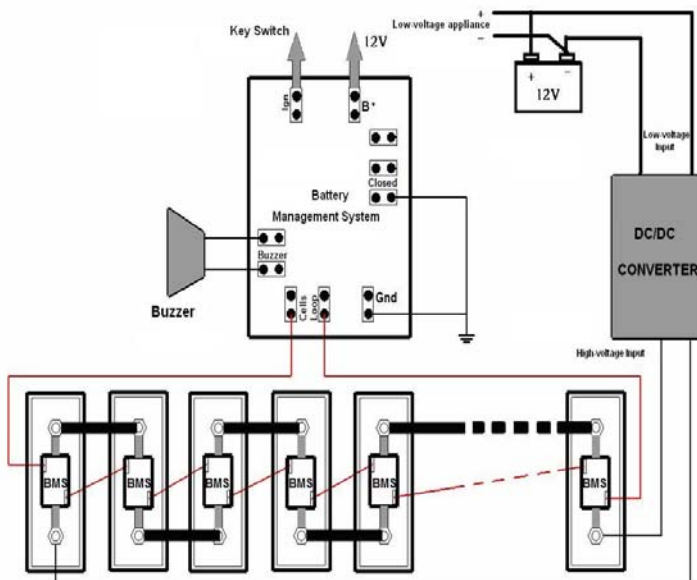

2. Basic Function

- 2.1 It can convert the high voltage DC to 12V low voltage DC
- 2.2 The charging of 12V backup battery can be controllable
- 2.3 Indicate the working status, fault code etc through DC/DC panel by LED

2.4 Protection function such as input low-voltage protection, input reverse connection protection, DC/DC over-temperature etc.,

2.5 Fully sealed, water-proof, no fans, natural convection air-cooling

3. Technical Parameter

3.1 Input

3.1.1 Input voltage

The input currents under different input voltages (See table below). Allowed voltage range is 280V~380V

Input Voltage (V)	Input Current I_N (A)
280	$I_N \leq 4$
320	$I_N \leq 3.5$
380	$I_N \leq 3$

3.1.2 Input low-voltage protection

Input Voltage (V DC)	Protection Point
	$200V \pm 20V$

3.2 Output Spec

Item	Rated Value	Error Limitation
DC output voltage-Max	13.6V	$\pm 0.1V$
DC output current-Max	70A	$\pm 1A$
DC output power-Max	1000W	/
Efficiency	$\geq 89\%$	/

3.3 Usage environment

Item	Applicable Environment	Remark
Operating Temperature	$-30 \sim 60^\circ C$	
Storage Temperature	$-45 \sim 90^\circ C$	
Operation relative humidity	$5\% \sim 95\%$	No condensation

3.4 Protection grade

Standard	Grade
GB4208-2008	IP66

3.5 Impulse Starting Current: Less or equal to 5A

3.6 Electrical Insulation

3.6.1 Voltage-withstand Performance

Terminals to earth (shell) and the dielectric strength of circuits without electrical connection to each other should withstand the test voltages. The testing voltage is AC voltage 50~60Hz. Test between terminals should not be a corona, ionization, arcing or breakdown phenomenon.

Input/Shell	1500VAC	1min	Leakage Current≤10mA
Input/Output	1500VAC	1min	Leakage Current≤10mA
Output/Shell	500VAC	1min	Leakage Current≤10mA

3.6.2 Insulation Resistance

The insulation resistance between live circuit and ground (shell) is not less than 20MΩ under the environmental temperature (23±2) °C and relative humidity 80% ~ 90%.

3.6.3 Contact Current

Contact Current	AC Current mA	DC Current mA
Limit	/	2

3.7 Noise

Noise	Condition
≤55dB	Distance 1.5m, A weighted noise

3.8 Grounding resistance

3.8.1 The grounding resistance is not more than 0.1Ω.

3.8.2 Grounding wires must be yellow/green double color.

3.9 EMC Properties

EMC accords with the article 11.3 of the electromagnetic environment test requirements in GB/T 18487.3-2001

3.10 Protection Features

- a) Input Under-voltage Protection;
- b) Output Over-voltage Protection;
- c) Output Over-current Limitation;
- d) Output Short-circuit Protection;

e) Input Reverse Connect Protection;

f) Battery Temperature Protection

3.11 Wire-harness

	Wire Core	Protection Requirement
AC Input	2.5mm ²	Cover orange corrugated pipe
DC Output	16mm ²	Cover black corrugated pipe
12V ENABLE	0.75mm ²	Cover black corrugated pipe

3.12 Reliability

Reliability is figured out by the device's failure rate.

Index	Data Definition
MTBF	150,000 H

4. Installation Dimension

Peripheral largest size (L x W x H):

281mm(11.06")*245.5mm(9.67")*109.5mm(4.31")

